

PROGETTO

SCHEDA PER PIC 18F4550

Aggiornato il 6 gennaio 2007



di Adriano Gandolfo
www.adrirobot.it

Elenco componenti scheda PIC 18F4550

C1	100nF multistrato
C2	100nF multistrato
C3	100nF multistrato
C4	470nF multistrato
C5	22pF ceramico
C6	22pF ceramico
D1	led rosso
D2	led rosso
D3	led rosso
D4	led rosso
D5	led verde
IC1	PIC18F4550 + zoccolo
IC2	TC77
JP1	jumper
JP2	jumper
JP3	jumper
JP4	jumper
JP5	jumper
P1	Pulsante da stampato
P2	Pulsante da stampato
P3	Pulsante da stampato
Q1	Quarzo 20MHz
R1	10k Ω 1/4W
R2	470 Ω 1/4W
R3	10k Ω 1/4W
R4	10k Ω 1/4W
R5	330 Ω 1/4W
R6	10k Ω 1/4W trimmer
R7	470 Ω 1/4W
R8	470 Ω 1/4W
R9	470 Ω 1/4W
R11	10 Ω 1/4W
R12	10 Ω 1/4W
R13	330 Ω 1/4W
R14	330 Ω 1/4W
R15	330 Ω 1/4W
R16	330 Ω 1/4W
R17	1M Ω 1/4W
RB	Connettore Header 8 Vie Molex Codice RS 360-6752
RD	Connettore Header 8 Vie Molex Codice RS 360-6752
X1	Connettore USB tipo B ad angolo PCB Codice RS 515-1989

Circuito stampato (100x66)



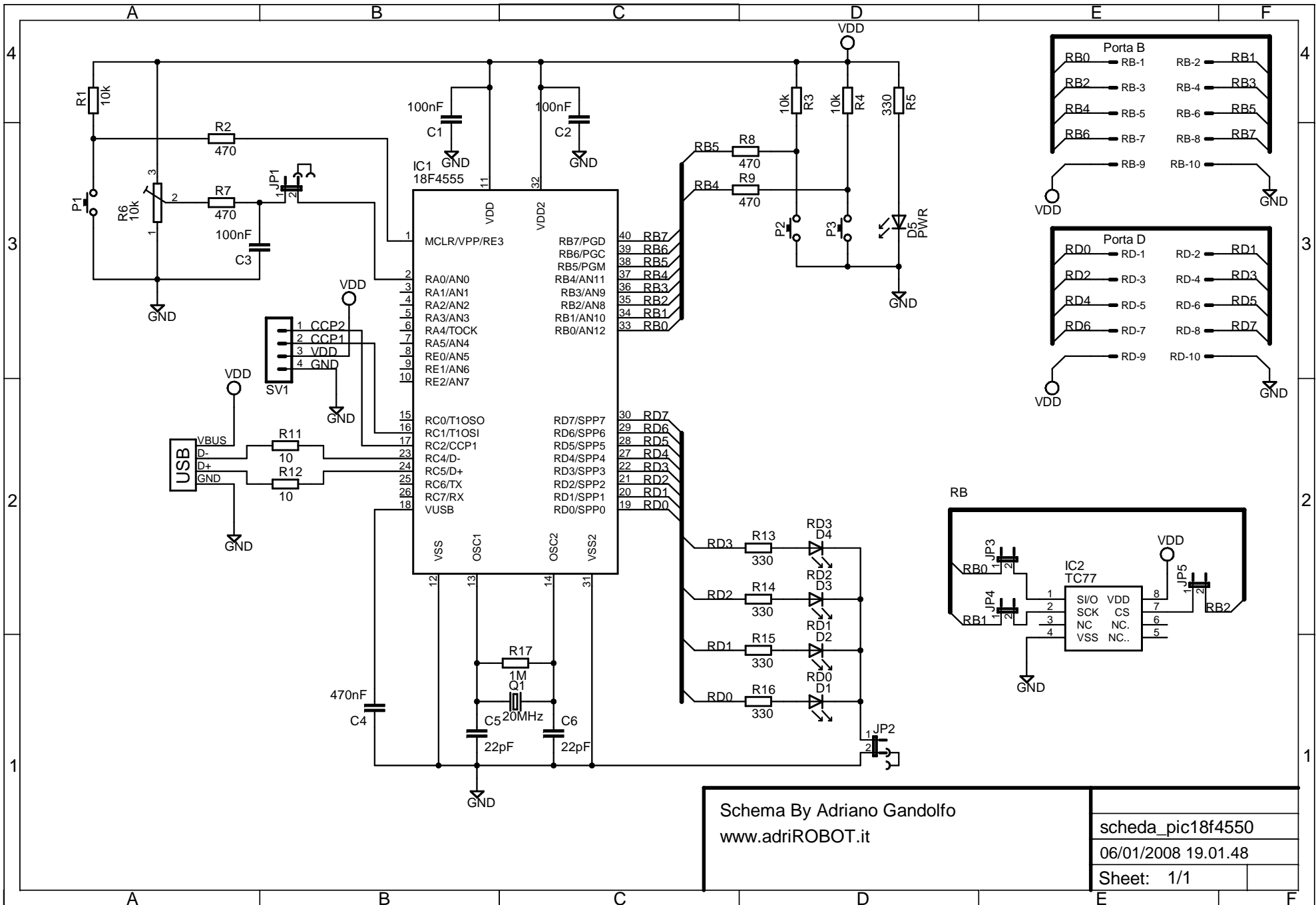

Schema By Adriano Gandolfo
www.adriROBOT.it

scheda_pic18f4550	
06/01/2008 19.01.48	
Sheet:	1/1

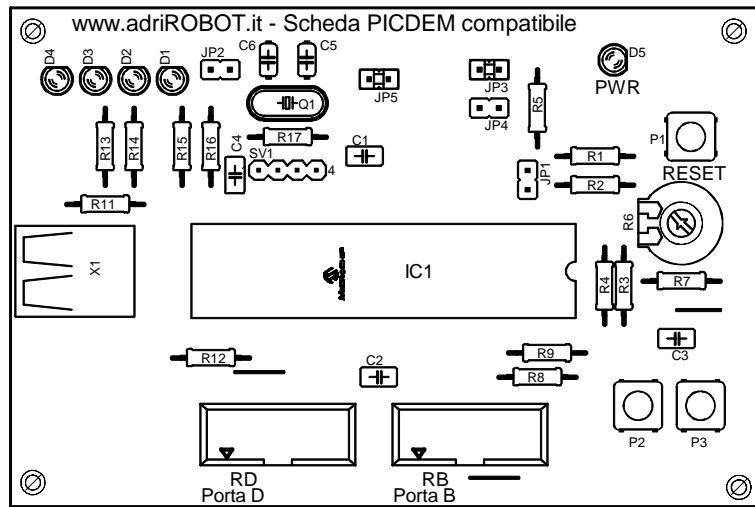

WWW.adriROBOT.it by Adriano Gandolfo

Date: not saved!

TITLE: scheda_pic18f4550

Sheet:

