

PROGETTO

SENSORE PER TELECOMANDO

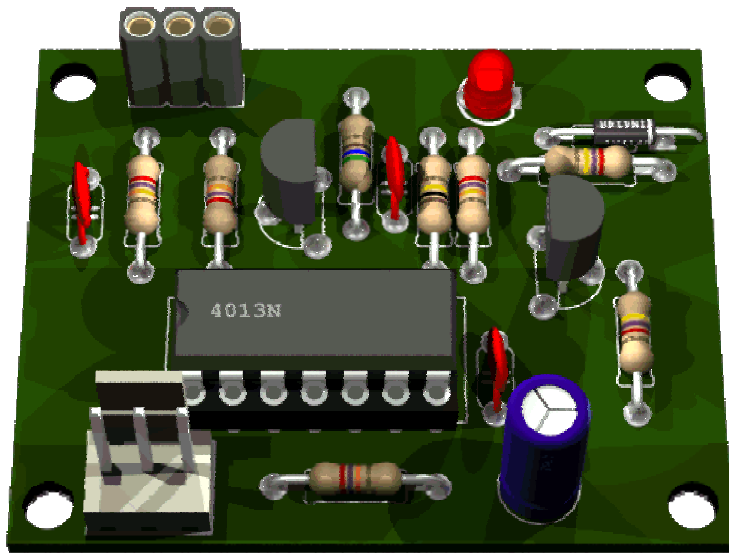

di Adriano Gandolfo
www.adrirobot.it

Elenco componenti

C1	470nF
C2	47 μ F elettrolitico
C3	100nF
C4	470nF
D1	Led rosso
D2	1N4148
Q1	BC558
Q2	BC548
R1	27K Ω 1/4W
R2	27K Ω 1/4W
R3	560 Ω 1/4W
R4	27K Ω 1/4W
R5	27K Ω 1/4W
R6	4K7 Ω 1/4W
R7	100K Ω 1/4W
R8	270K Ω 1/4W
U1	TSOP
U2	4013N
X1	Connettore maschio 3 pin

Dimensioni dello stampato 45x36mm

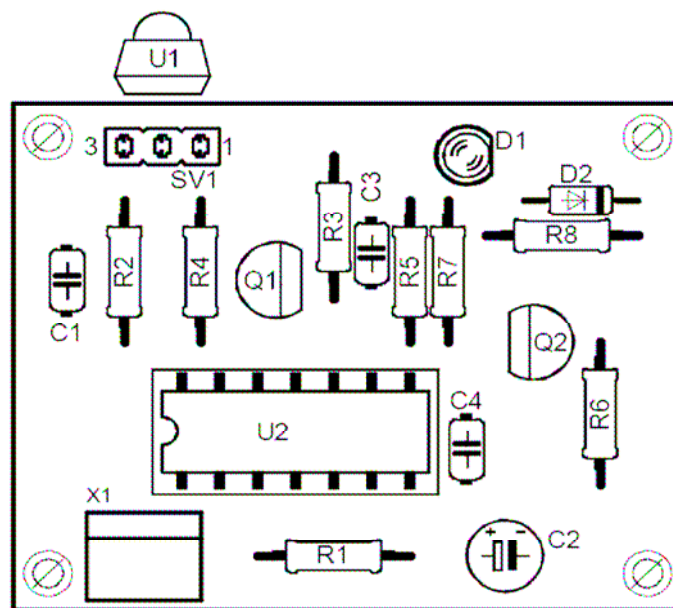

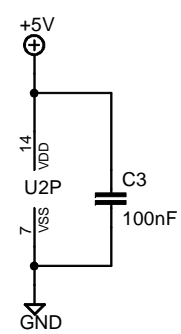
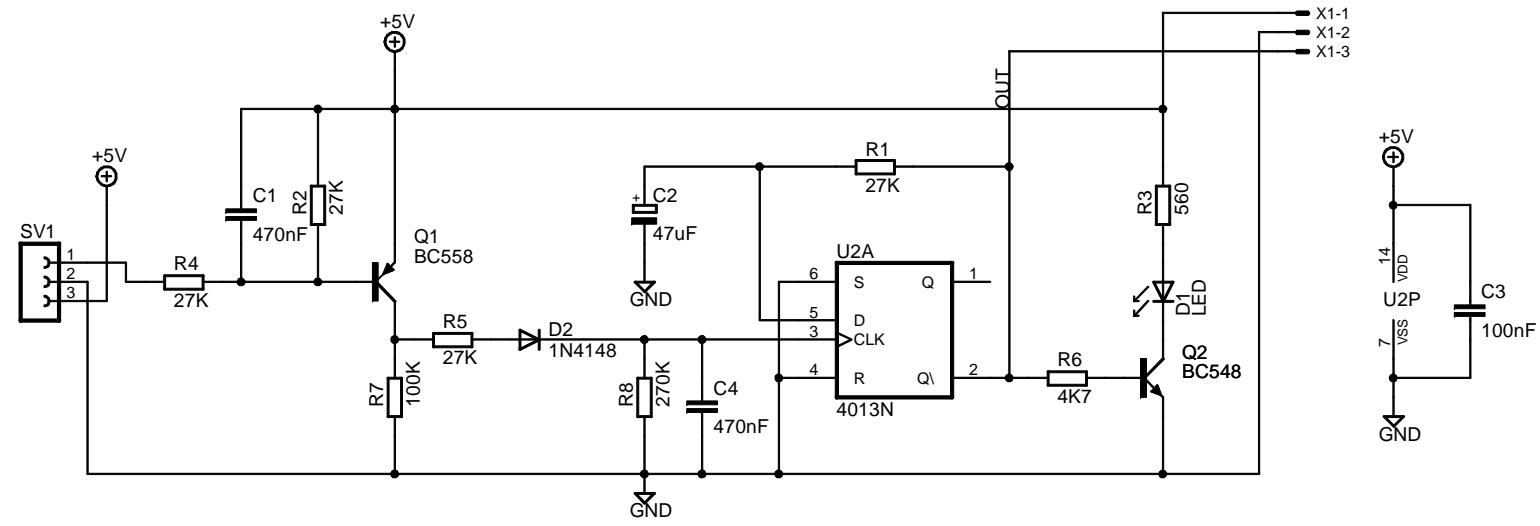
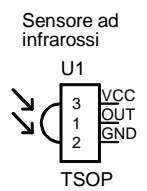

Schema By Adriano Gandolfo www.adriROBOT.it	
Sensore_infrarosso 22/11/2007 13.04.04	
Sheet: 1/1	

