

Power section

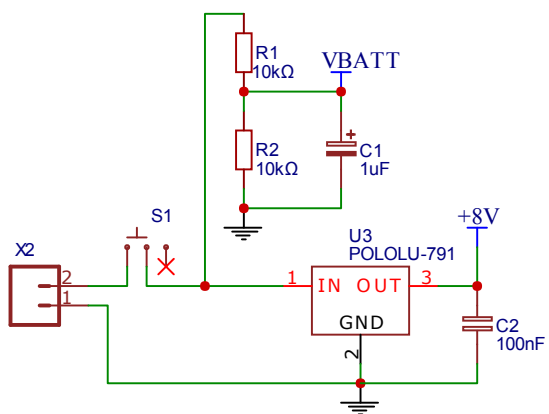

Controller

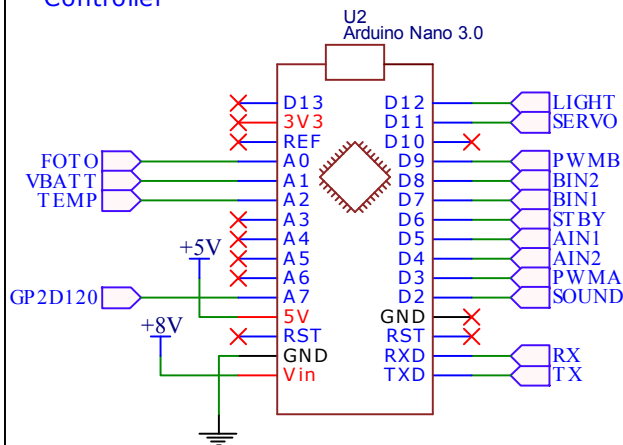

Motor Control

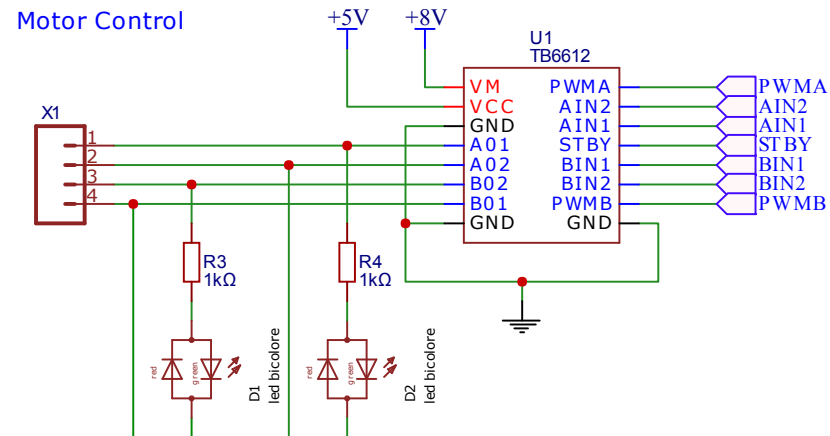

Buzzer

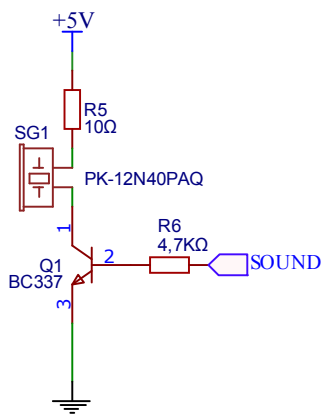

Light

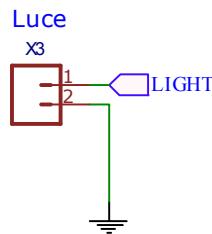

Light Sensor

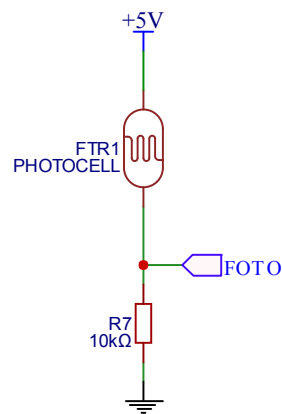

IR Sensor GP2D120

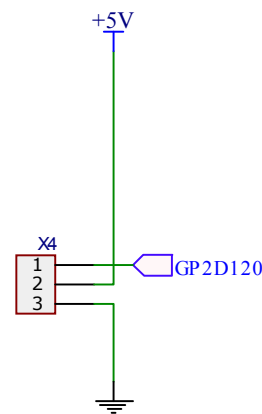

Servomotore

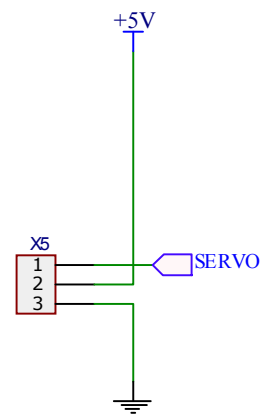

Temperature Sensor

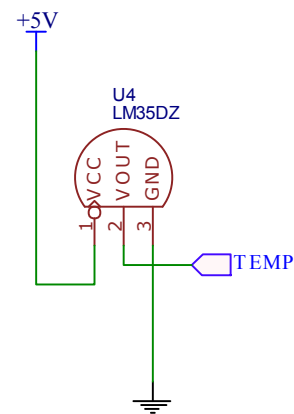

Bluetooth

